



Integrating Risk-Based Inspection Recommendations with Inspection Programs and Integrity Operating Windows

Lynne Kaley, PE

Principal

Trinity Bridge, LLC

Savannah, GA

W. Clay White

Fixed Equipment Network Lead

Phillips 66

Houston, TX



Introduction

- Risk-Based Inspection (RBI) has been widely used to optimize inspection activities in the industry starting in the 1990's
- RBI for pressure vessels has been generally accepted and easily managed
- Application to piping corrosion loops/systems in a manageable way has been more challenging
- Establishing Integrity Operating Windows (IOW's) using API 584 is an opportunity to manage fixed equipment and piping and integrate inspection activities with RBI
- Need to outline the steps for defining a piping inspection program using risk with corrosion loop & circuit definition and identification of IOW's
- Discuss challenges to inspection planning using risk for piping corrosion loops



Work Process

- Establish risk approach and basis for inspection plan development (inspection date, methods and coverage)
- Determine RBI unit scope, including fixed equipment and piping boundaries (typically includes primary piping and bypasses but not including utilities piping and piping after PRDs)
- Organize updated unit drawings and relevant data for analysis – P&IDs, PFDs, not necessarily including piping isometrics
- **Define corrosion loops and naming convention**
- **Circuitize piping within each corrosion loop**
- Conduct material/corrosion of all equipment included in unit study
- Create an database for calculation of risk and development of inspection plans
- Calculate Risk
- **Establish IOWs**
- **Develop Inspection Plans**



Considerations for Integrating RBI, IOWs and Piping Inspection

- Model Corrosion Loop as Equipment; Circuit as a component
 - Setting values to represent properties to model circuit
 - Circuit comprised of various components with varying rates, thicknesses and other properties
- When using RBI for piping inspection consider:
 - Basis for RBI modeling may not be representative for all components of the circuit, such as diameter, pressure, corrosion rate, corrosion allowance and t-min
 - Using average circuit corrosion rate from TML's/CML's may be non-conservative
 - Thicknesses of components in the circuit may vary
- Be careful when using a single thickness measurement and corrosion rate for multiple TML's/CML's



Definition of Corrosion Loops

- Corrosion Loop must be properly defined:
 - Corrosion Loops defined as equipment controlled together
 - In similar operating service
 - Expect similar corrosion mechanisms and rates
 - Share IOW criteria alerts and alarms
 - Controlled together operationally



Crude Unit PFD & Corrosion Loops

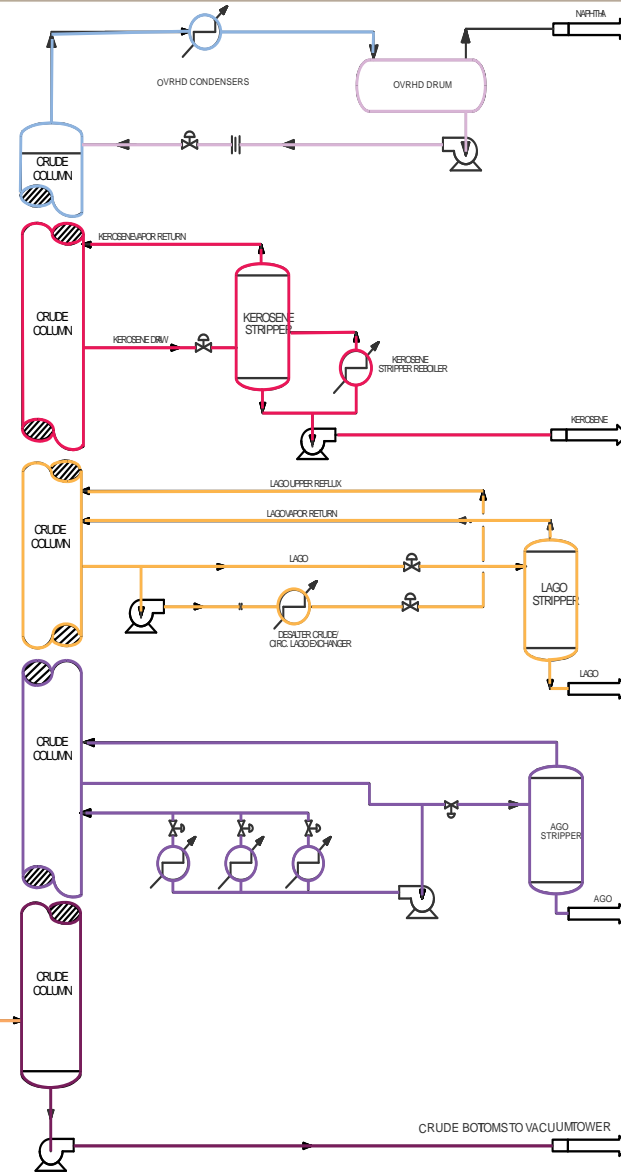
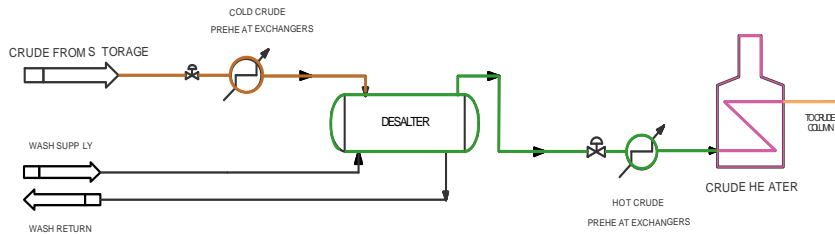



Define Circuits

- Goal: To create common inspection strategies for each circuit
- Corrosion Circuit must be properly defined:
 - Equipment with the same expected corrosion mechanisms and rates
 - Same material of construction
 - Same or very similar operating conditions
 - Equipment thickness measurements and calculated corrosion rates should be manageable as a group
- Define piping boundaries
 - Include all primary piping
 - Piping bypasses, start-up/shut-down lines
 - Piping up to PRD's
 - Normally does not include utility piping (e.g. air, nitrogen, steam), PRD relief system downstream piping



Establishing IOW's

- Based on Damage Review Conducted
 - 2 Approaches, Historical Operating & Limiting component
 - Identify potentially active damage mechanisms for all fixed equipment and piping corrosion loops/circuits
 - Assign estimated or measured damage based on service experience
 - Identify **process variables** driving in-service damage
- Established limits for **process variables** affecting the integrity of equipment
- Identify process operation deviating from established limit for a predetermined amount of time
 - Operating variables effecting reliable operation of the equipment
 - Operating variables determined as Critical, Standard and/or Informational
 - Appropriate limits for Critical and Standard windows
- Critical and Standard limits are normally established for a corrosion loop or system but are based on the equipment or component limiting the corrosion loop

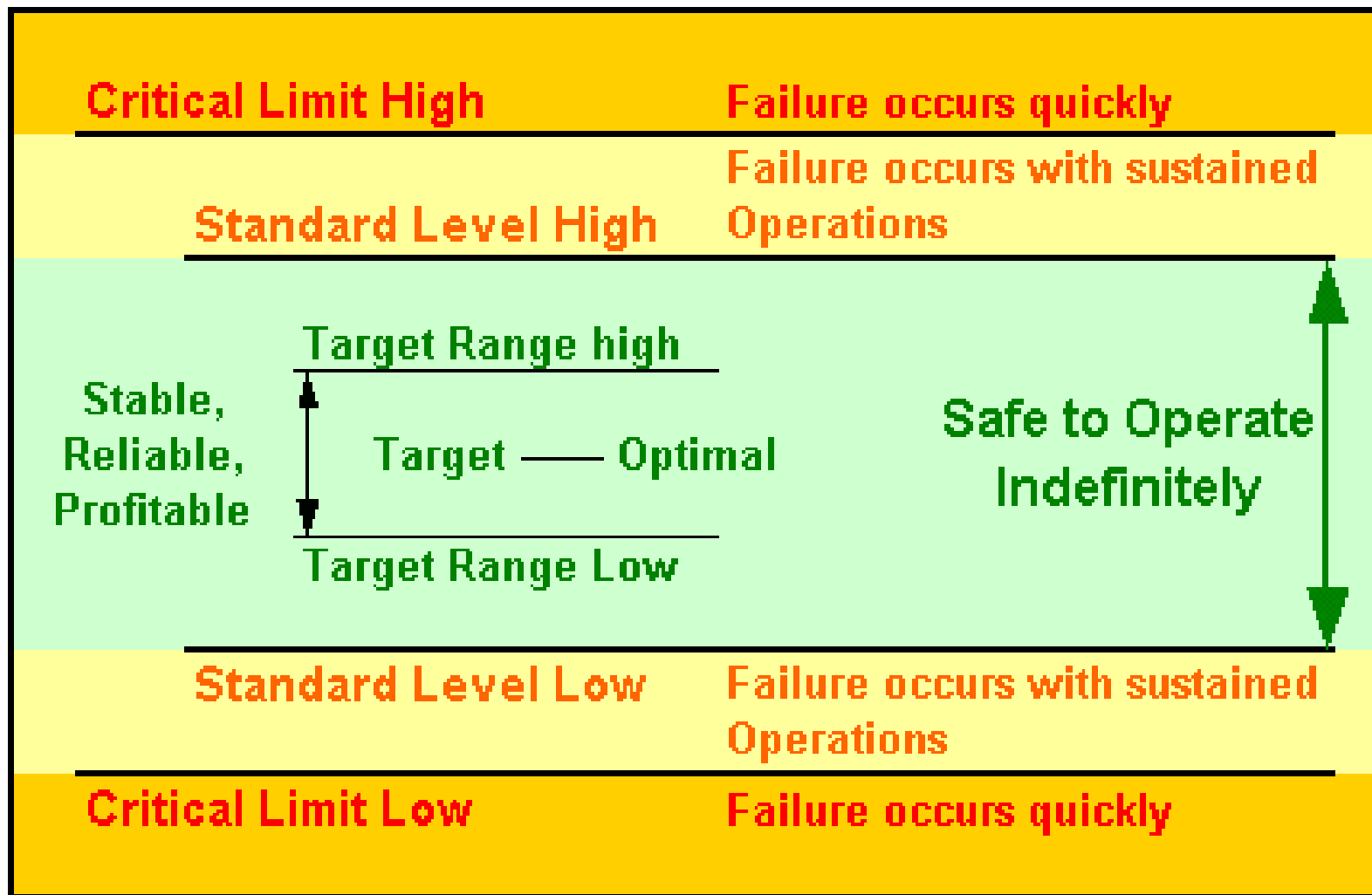



Crude Unit PFD & Corrosion Loops

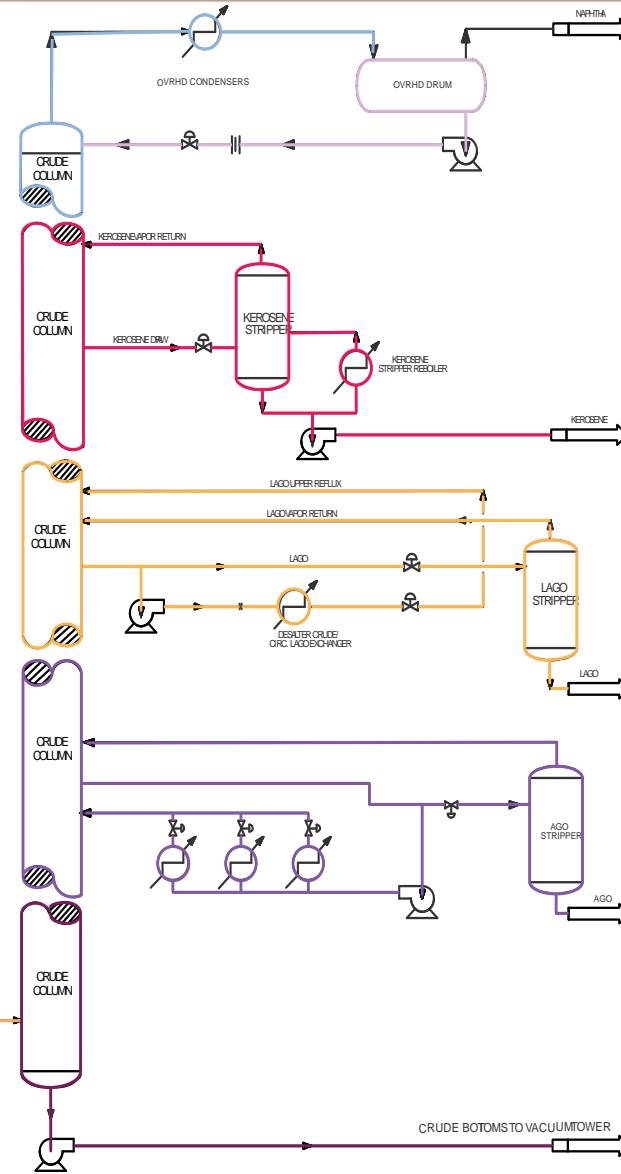
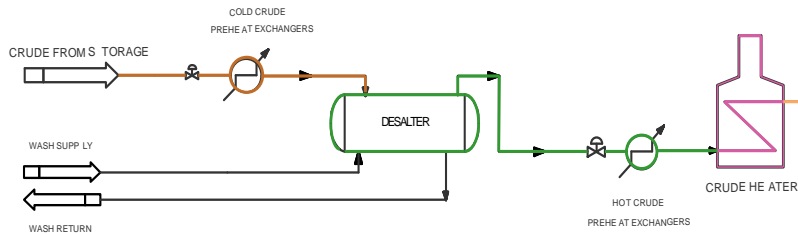



Crude Unit Corrosion Loop Descriptions

Corrosion Loops for Refining Units

Crude Unit

Crude Preheat

Desalted Crude Preheat

Desalted Water

Crude Furnace

Atmospheric Crude Transfer Line

Atmospheric Column Top and Reflux

Atmospheric Column Heavy Naphtha P/A

Atmospheric Column Kerosene Stripper & P/A

Atmospheric Column Diesel Stripper & P/A

Atmospheric Column AGO Stripper & P/A

Atmospheric Column Bottom Resid & Reboiler

Crude Unit Atmospheric Overhead

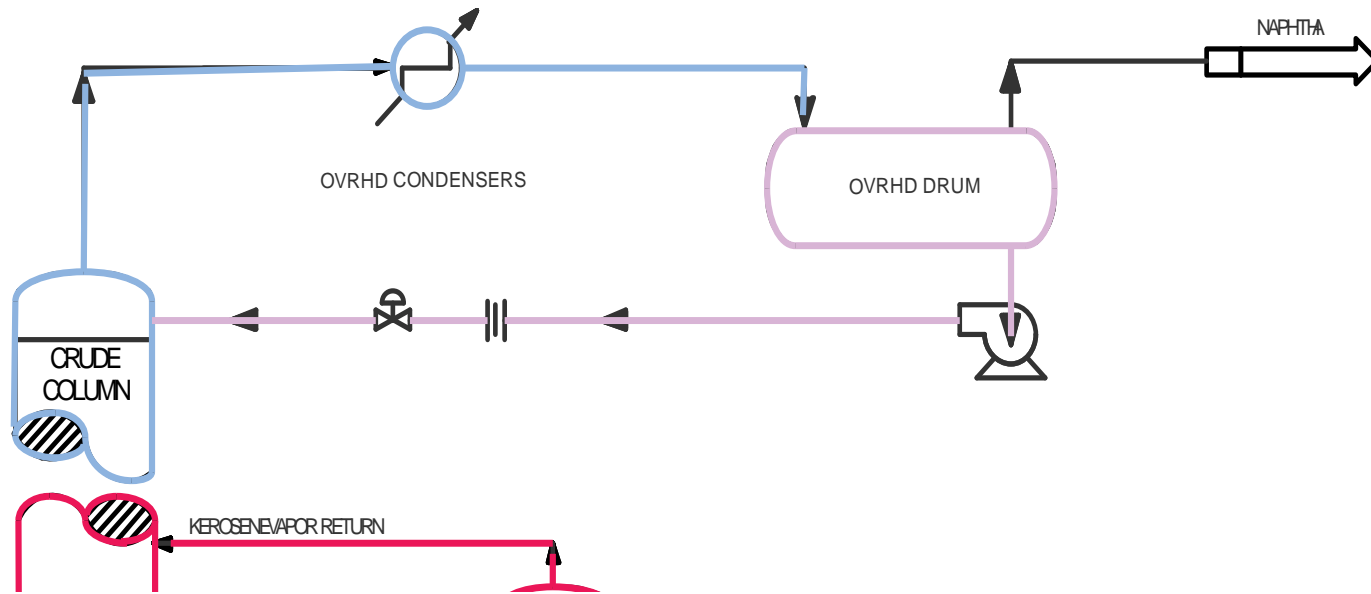



Crude Unit Atmospheric Overhead

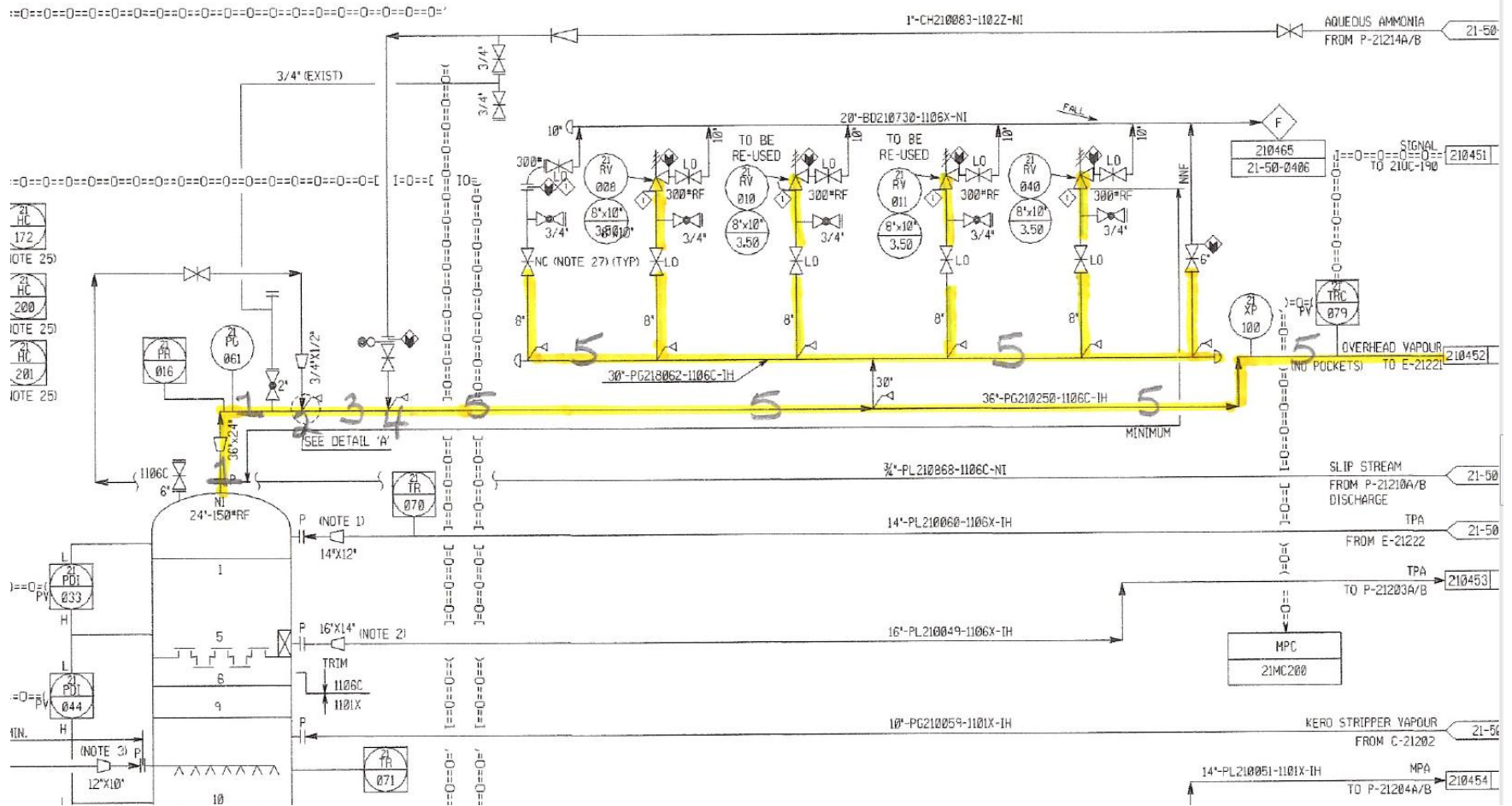



Corrosion Loop Description

- Consists of the overhead of Crude Distillation Column through Overhead Condensers and to Overhead Accumulator
- Operates at an average pH of 6.0 (range of 4.8 to 8.0). Operating temperature ranges from 221^oF to 122^oF. The primary concerns in this loop are hydrochloric acid corrosion at or below the dew point and mix point/injection point corrosion near each of the injection points. All piping in this loop is carbon steel materials of construction.
- Specific Corrosion Mechanisms:
 - Chloride corrosion due to Hydrochloric Acid for all materials of construction at temperatures below water dew point.
 - Injection/Mix point corrosion (localized) due to use of ammonia, inhibitor and neutraliser use.
 - SSC and HIC/SOHIC in Wet H₂S service.
 - Corrosion Under Insulation (CUI) potential at temperatures less than < 177^oC (350^oF)



Corrosion Circuit Definition

Circuit 1 – Carbon Steel

Circuit 1 consists of piping from the top of C-21201 Crude Distillation Column (from Tray 1 to top head) to the overhead line Chemical Injection point.

C-101 Top outlet: 221°F

- Estimated Corrosion Rate Average – 6 mpy
- Corrosion Type – Localized
- Primary Damage Mechanism – Aqueous HCl
- Secondary Damage Mechanism – Potential aqueous H₂S
- Specific Location Concerns – Aqueous corrosion at or below the dew point in carbon steel overhead line



IOW's

Process Equipment	Sample Location	Test Analysis	Frequency
D-101	Accumulator Sour Water	pH 5.5-6.5 Chloride < 50 ppm Fe <2.0	3 times/week 3 times/week 3 times/week
Overhead line	Overhead line	Injection points	3 times/week

Process Equipment	Alert	Alert Response
D-101	pH <5.5 or >7.5 Chloride > 50 ppm Fe > 2.0 ppm	Check neutralizer injection Check caustic injection Check ammonia injection



Vacuum Unit PFD & Corrosion Loops

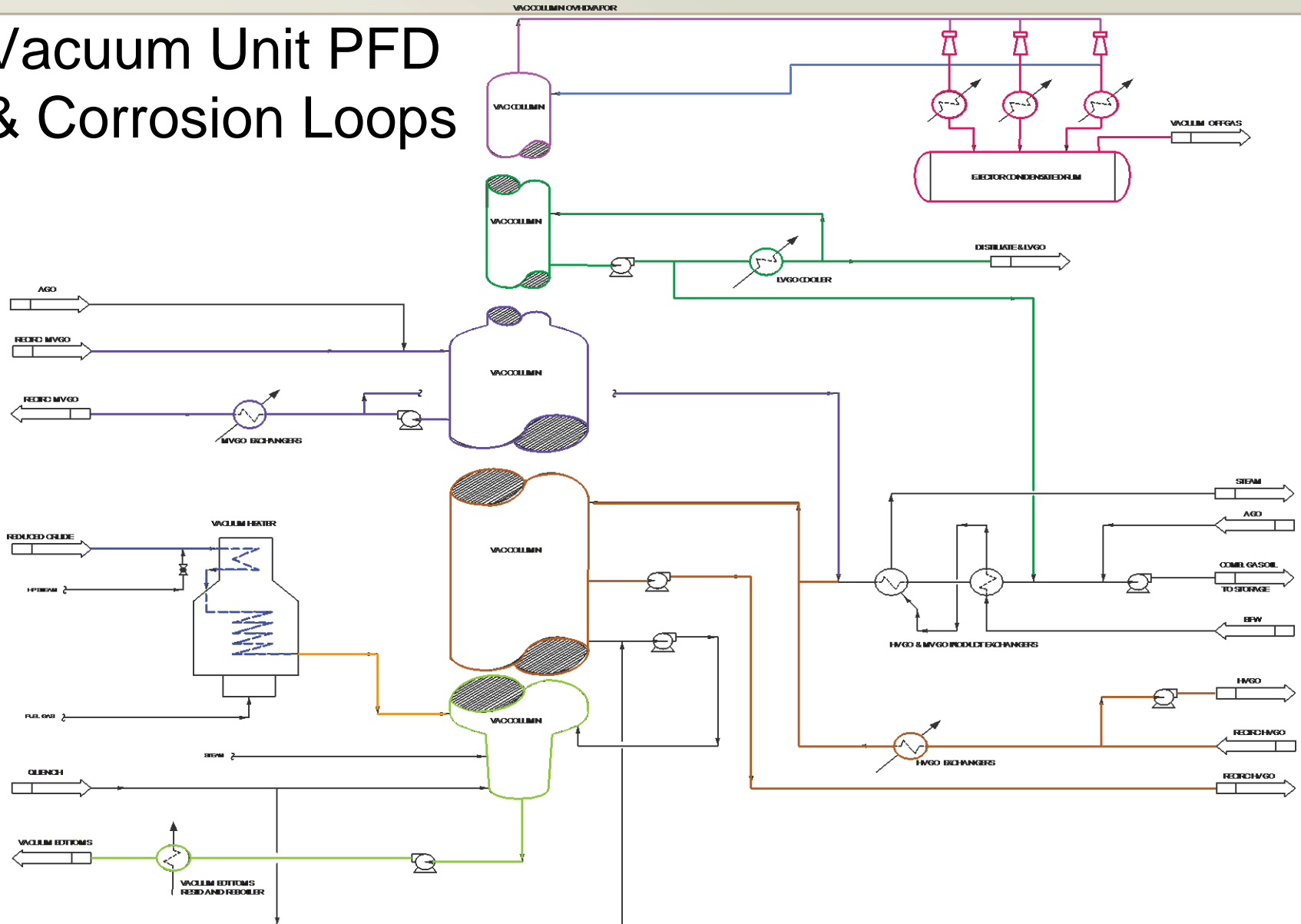



Vacuum Unit Corrosion Loop Descriptions

Vacuum Furnace

Vacuum Transfer Line

Vacuum Column Top & Reflux

Vacuum Column Eductor System

Vacuum Column Top P/A

Vacuum Column LVGO & P/A

Vacuum Column MVGO & P/A

Vacuum Column HVGO & P/A

Vacuum Column Bottom Resid and Reboiler

Vacuum Column HVGO Corrosion Loop

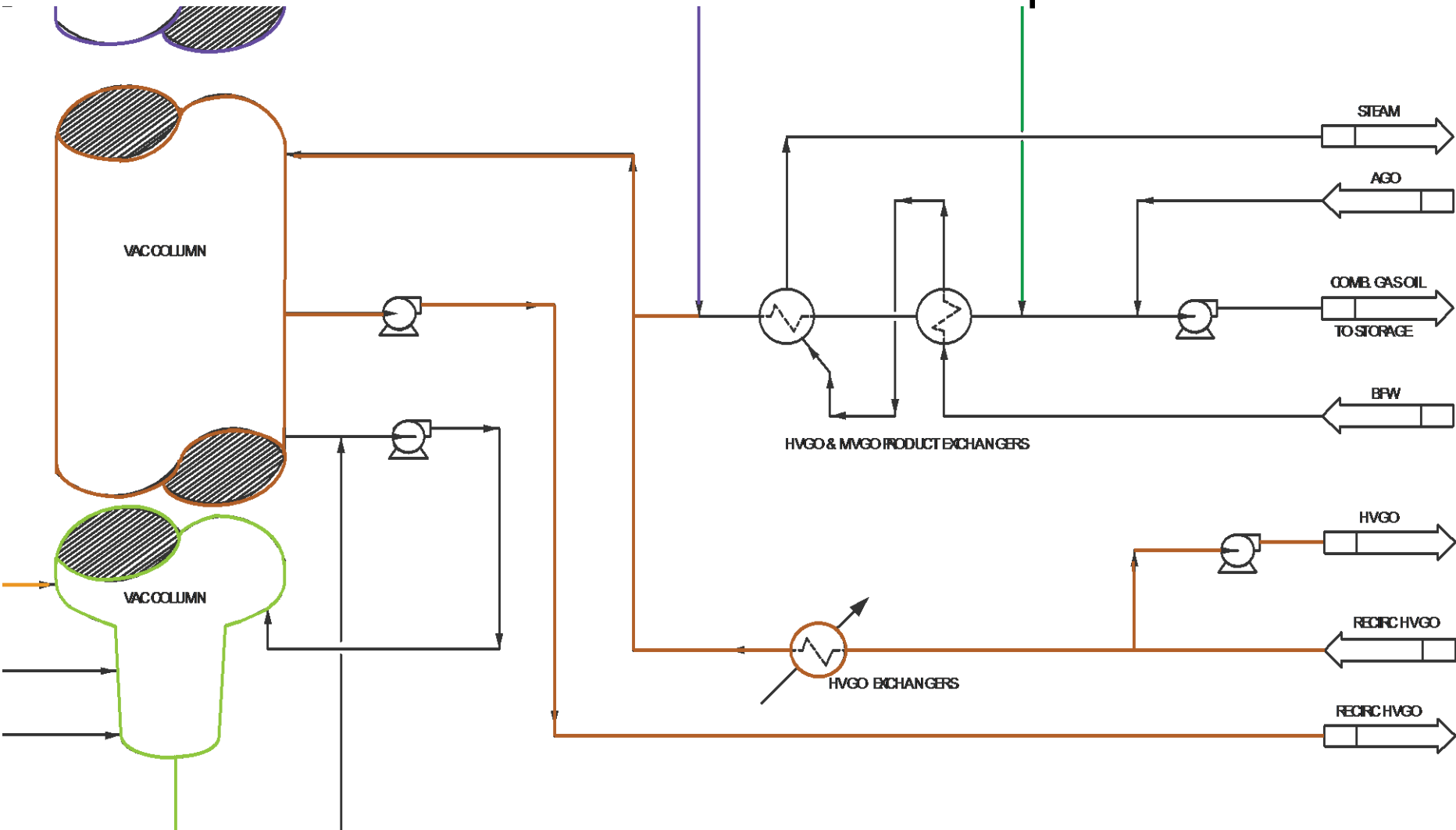

Vacuum Column HVGO

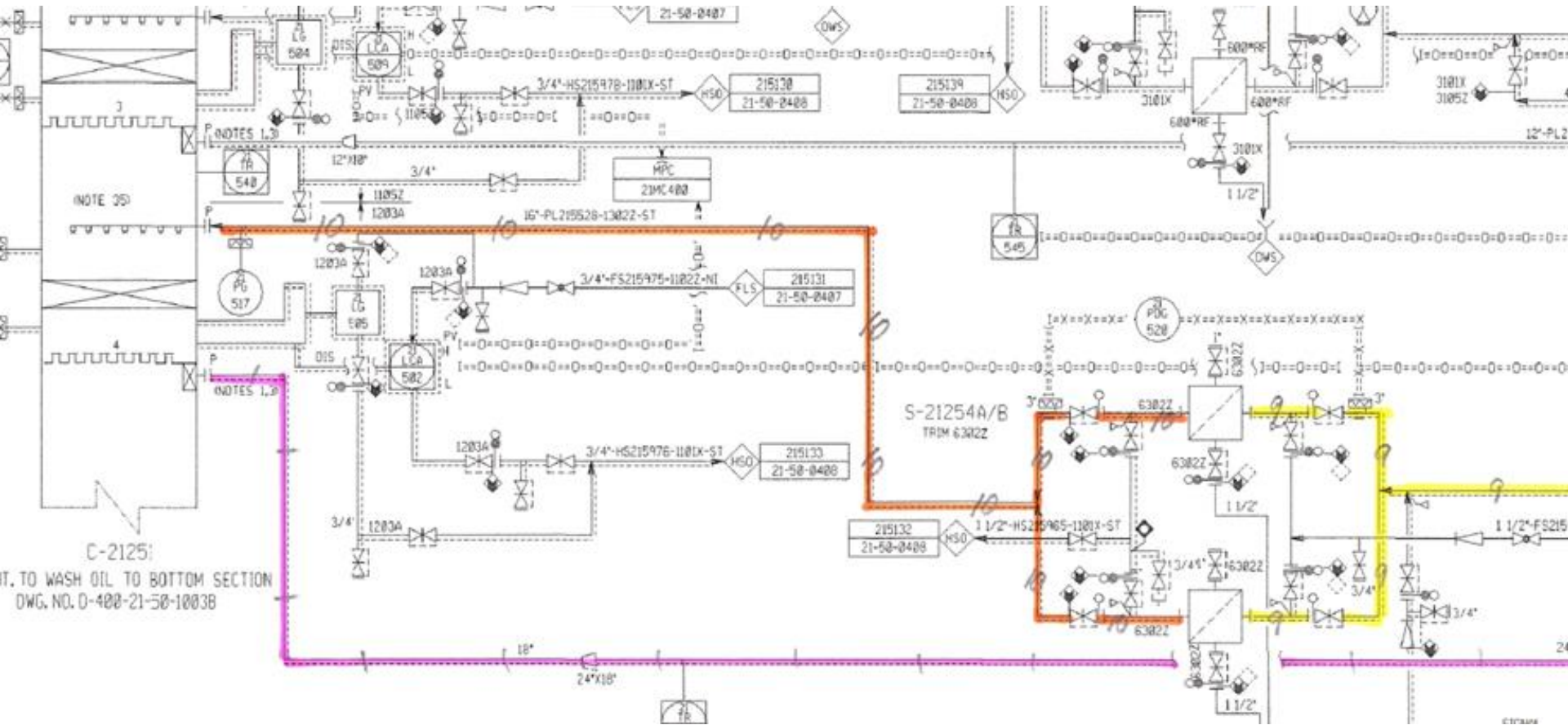



Corrosion Loop Definition

- Consists of the HVGO draw at 577°F to HVGO pumps A/B and split with a portion returning to the column under flow control as wash oil. A split HVGO stream is cooled in the hot preheat train exchangers A/B and cold preheat train exchangers, combined with MVGO and cooled to 150°F and sent to storage.
- HVGO stream contains an average of 2.5 wt% sulfur (maximum 3.9%) and average 0.9 (maximum 1.8) TAN. Operating temperature ranges from 554°F from the draw tray down to 150°F for product rundown
- Primary concern in this loop is for Sulfidation and/or Naphthenic Acid corrosion which are most active in circuits operating above 450 °F
- Corrosion Loop contains a mixture of 5 Cr – ½ Mo, Type 316L and carbon steel materials of construction



Corrosion Loop Definition

- Specific Corrosion Mechanisms:
 - Sulfidation and/or Naphthenic Acid corrosion based on % total sulfur and TAN in HVGO stream and temperatures $< 350^{\circ}\text{F}$
 - Injection/Mix point corrosion (localized) due to use of water and chemical inhibitor use for Circuit 2 and Circuit 5
 - Corrosion Under Insulation (CUI) potential at temperatures less than $< 350^{\circ}\text{F}$
- Corrosion rates are based on:
 - Modified McConomy curves for sulfidation rates
 - API 581 for rates based on the presence of sulfur and naphthenic acid
 - Corrosion is generalized in piping straight runs and can be highly localized in turbulent flow areas when TAN values are greater than 1.5
 - Rate and thinning type (generalized and localized) is influenced by sulfur, TAN and velocity



Corrosion Circuit Definition

Circuit 1 – 5 Cr-½ Mo

Circuit 1 consists of piping from Tray #4 in Vacuum Column to the chemical injection point.

Vacuum Column draw: 554°F

- Estimated Corrosion Rate Average
- Sulfidation (generalized) – 6.2 mpy
- Sulfidation/Naphthenic Acid (localized) – 6.8 mpy
- Primary Damage Mechanism – Sulfidation and/or Naphthenic Acid corrosion
- Secondary Damage Mechanism – None
- Specific Location Concerns – Possible general corrosion in deadlegs associated with bypasses; localized corrosion potential in turbulent flow areas such as direction changes, piping associated with pumps, reducers, mixed phase flow, etc.



IOW's

Process Equipment	Sample Location	Test Analysis	Frequency
HVGO	HVGO	Sulfur 2.5% TAN 1.0	HAC Runs

Process Equipment	Alert	Alert Response
HVGO	≥ 3 Sulfur > 1.25 TAN	Review crude blending and check corrosion probes



Approaches to Inspection Planning for Piping

- Handling of CML/TML data from inspection for analysis
 - Use circuit data for analysis with careful use of TML/CML data
 - High Quality, sanitized UT (don't mix with RT or other methods)
 - Select corrosion rates for analysis
 - Select representative measured thickness for analysis
 - Develop inspection due date, coverage and methods
- Interval-Based vs. Risk-Based
 - ½ life interval basis does not consider COF
 - Risk-Based interval may not reflect risk of all components
 - Quantitative and even qualitative risk analysis at the component and TML/CML level is not practical



CML/TML Data – All Data

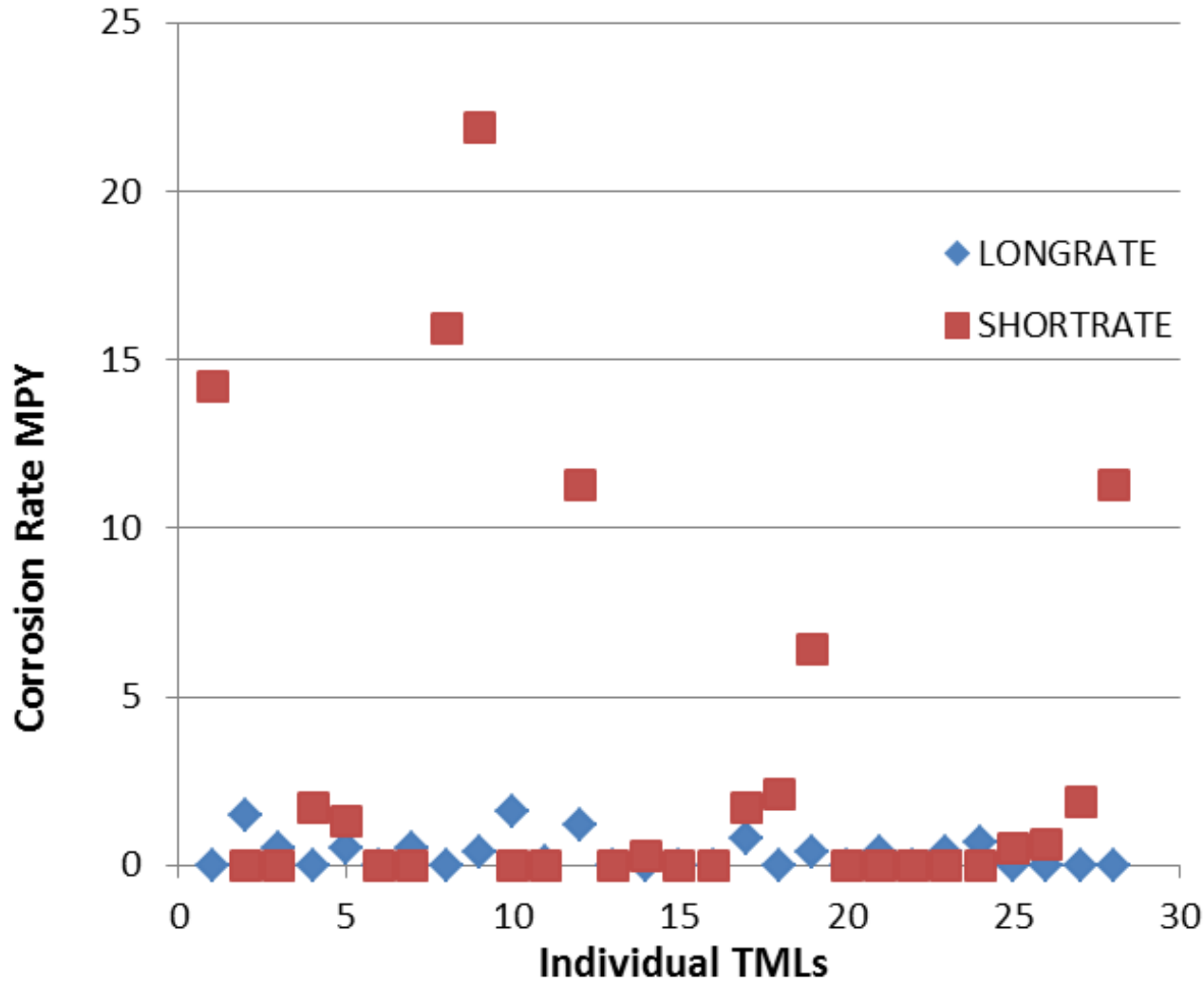



CML/TML Data – Carbon Steel, UT and RT Methods

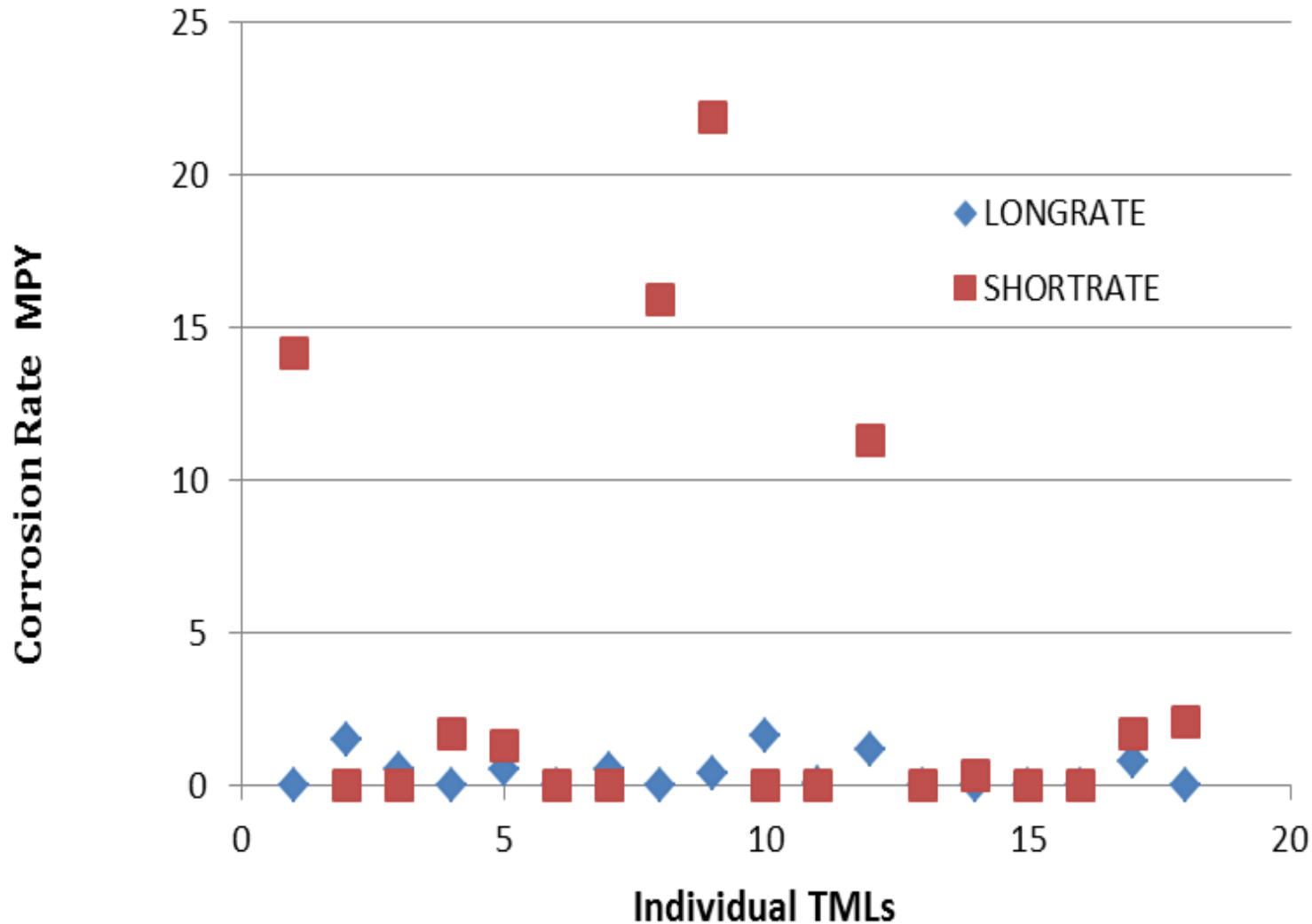



CML/TML Data – Carbon Steel, UT Method Only

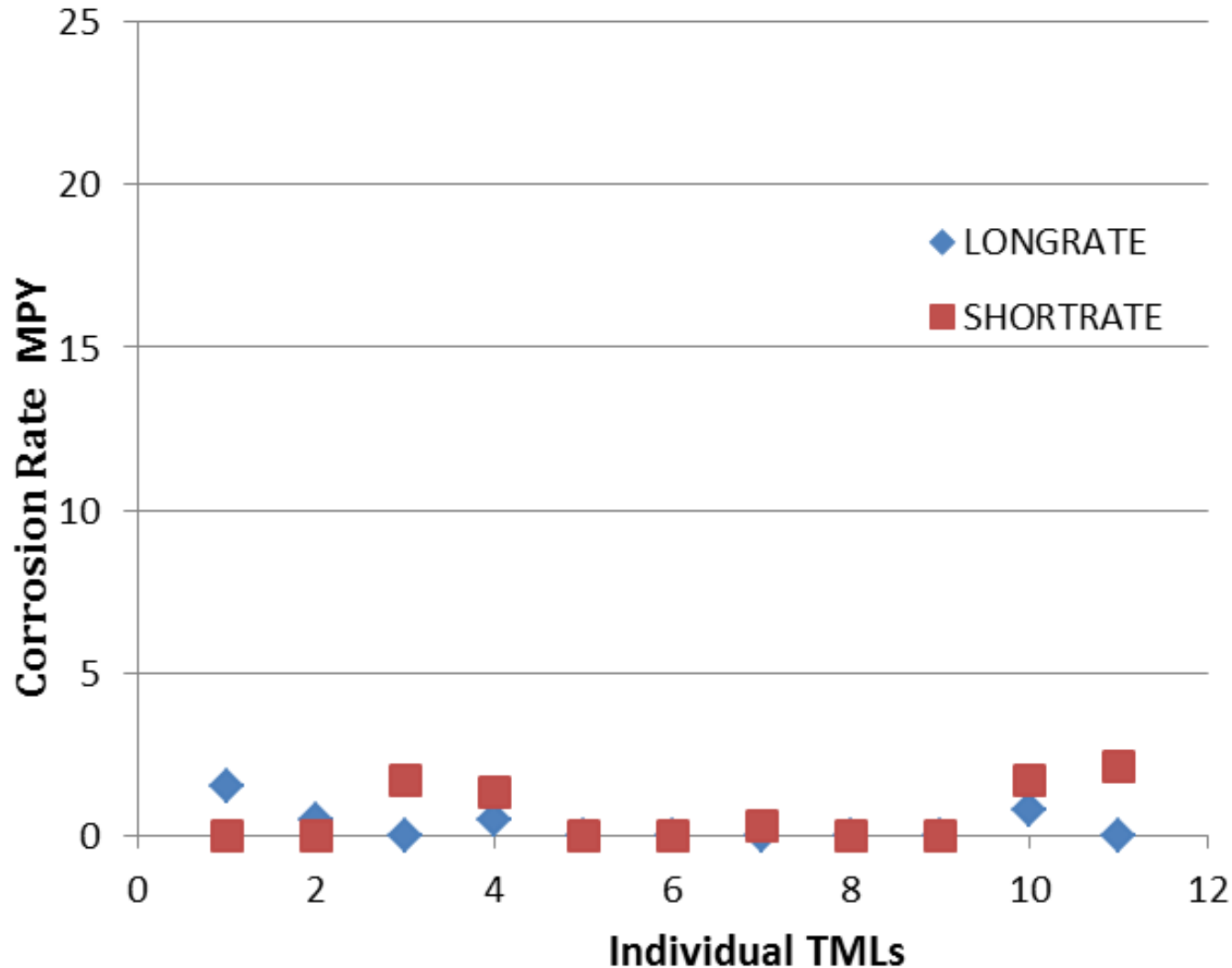



Interval-Based vs. Risk-Based Programs

Interval-Based

- t-min & 1/2-life determination
- Often includes a maximum frequency
- No COF consideration
- Probability based on damage rate only
- Nominally B-Level effective inspection

Risk-Based

- Optimized inspection based on risk
- Reduced inspections for low consequence equipment
- Credit for probability assessment
- Multiple levels of inspection effectiveness



Inspection Planning Approaches

- ½ Life Inspection – performed on or before equipment reaches ½ life based the shorter of t-min and corrosion rate or max interval
- Risk Target – Risk escalates with time requiring inspection on or before the date the risk target is reached (POF/Damage Factor or COF)
- Inspection Frequency – performed on or before a maximum frequency as determined by risk based matrix location
- Frequency Adjustment Factor – performed on or before a remaining life adjusted interval, determined by risk based matrix location



Risk and Inspection Planning for Piping

- Quantitative RBI and many qualitative approaches are too complex for managing piping components
- TML/CML inspection can be managed at circuit or individual TML/CML locations
- POF can vary significantly among components within a circuit while COF is relatively constant
- COF can be used for piping components and TML/CMLs to adjust inspection dates and coverage
- Inspection intervals can be modified with consideration for COF (similar to API 570 classification)
- Remaining life calculations and adjustment factors can be defined with consideration for COF in place of $\frac{1}{2}$ life

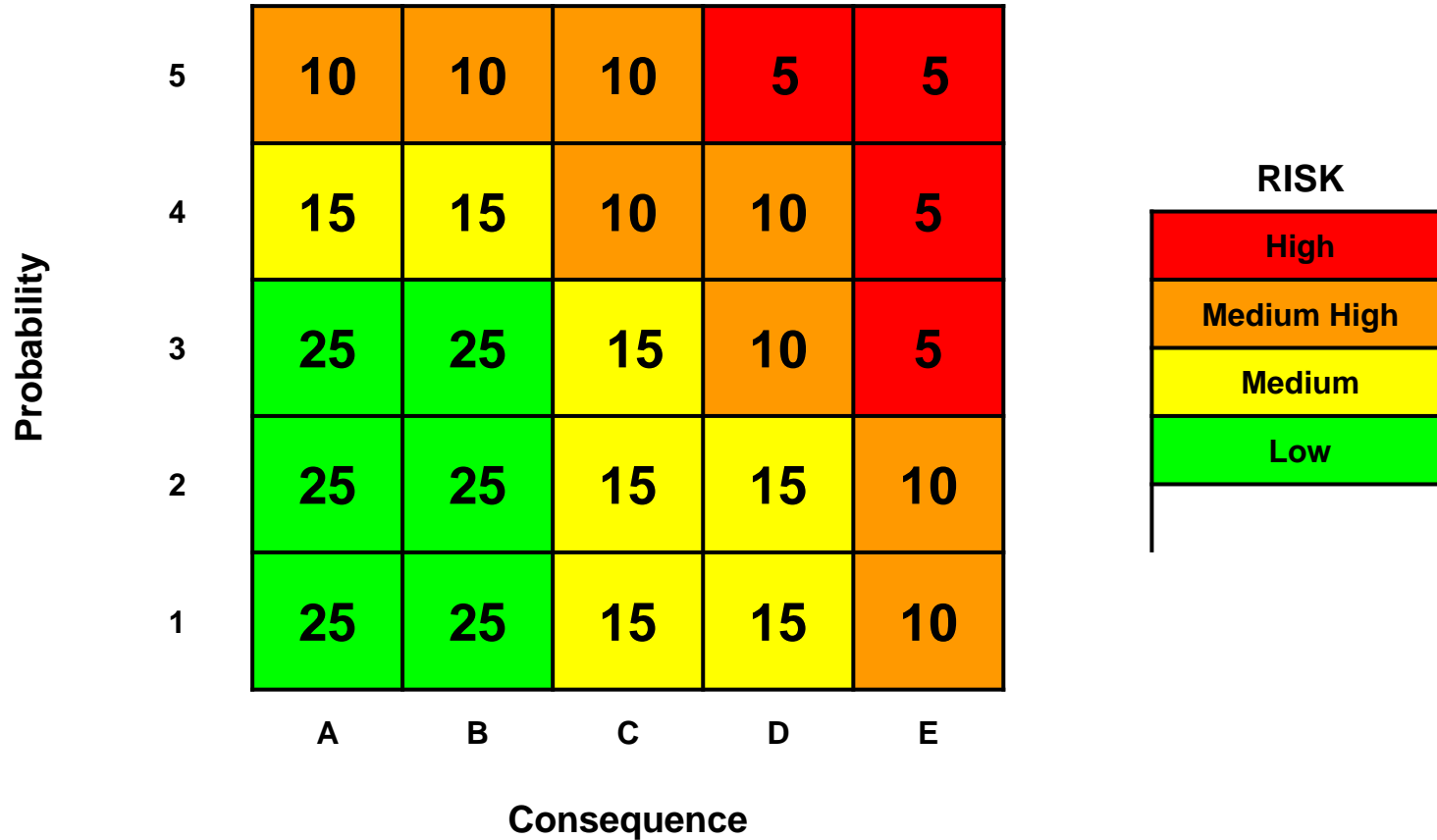

Risk Matrix with Maximum Inspection Interval

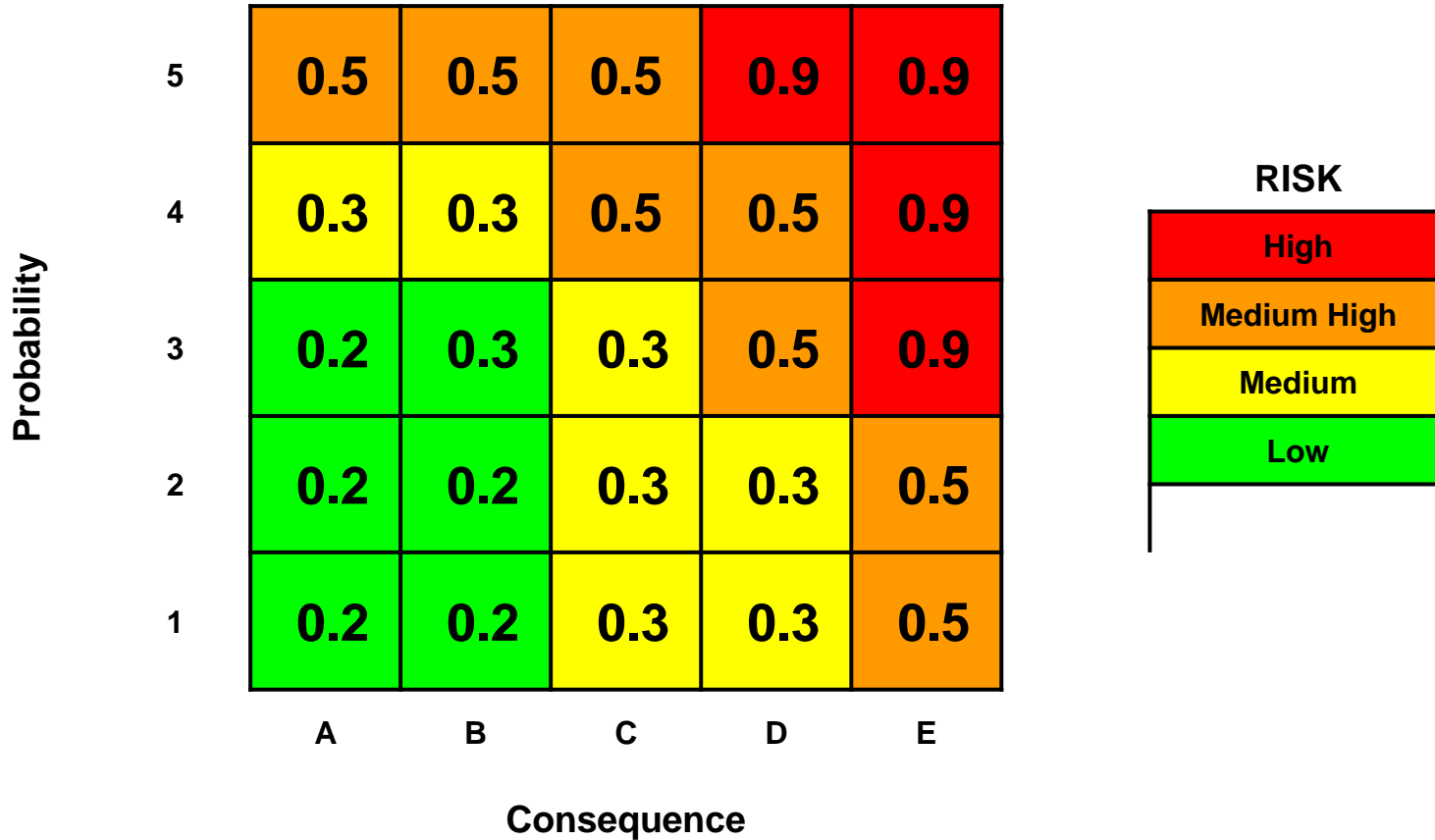

Risk Matrix with Remaining Life Adjustment Factor

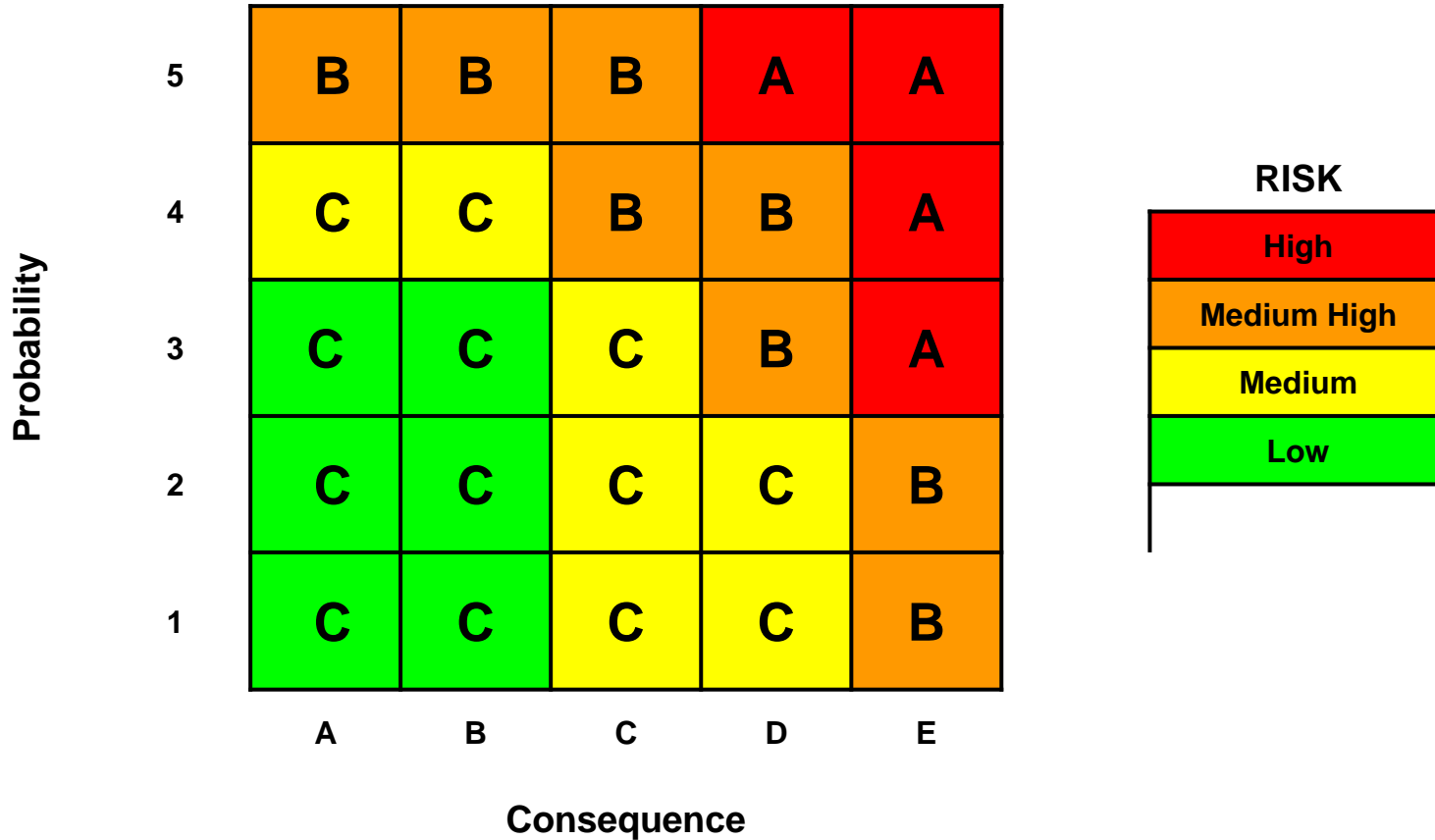

Risk Matrix with Inspection Effectiveness



Piping Inspection Planning

- Determine the basis for POF, Risk and inspection planning
- Define inspection & coverage can be applied to circuit
 - Inspection of circuit can be based on remaining life and/or POF of components based on TML's/CML data
 - Inspection Effectiveness, i.e. coverage percentage, can be defined for low risk circuits, higher coverage to high risk circuits
- Requires good integration between RBI and IDBMS program for information exchange between modules



Conclusions

- Starting with defining corrosion loops and circuits, combining equipment and piping
- Build out your RBI program for equipment and selectively model a representative portion of the piping circuit
 - Average primary component
 - Limiting component
 - Other
- Determine logic for adjusting piping inspection, using risk/consequence to adjust interval or scope
 - Adjusting life fraction (1/2 life)
 - Adjusting scope (number of inspection points)



Conclusions

- Model Corrosion Loop as Equipment; Circuit as a component
 - Can use average or weighted average values to represent properties to model circuit
 - Circuit comprised of various components with varying rates and other properties
- When using RBI for piping inspection consider:
 - Basis for RBI modeling may not be representative of all components in the circuit, such as component remaining life, pressure, corrosion rate, corrosion allowance and t-min
 - Average corrosion rates may be non-conservative for some components
 - Thicknesses of some components in the circuit may vary
- Be careful when using a single thickness measurement and corrosion rate for multiple TML's/CML's



INSPECTION
SUMMIT
2015